

BILL of MATERIALS

Qty.	DESCRIPTION
1	ROCHESTER SENDING UNIT, DBL PLATED
1	ALUM. PL3 PICKUP W/O BARB
1	3/8 NPT INSERT W/ 5/8" BARB (VENT)
1	Ø1.50 X 2.75 MOLDED FILL
	OVERALL HEIGHT 17.25"

NO.	REVISION	DATE
1	REPLACE P/U W/ PL3 P/U, & MOLDED FILL & VENT W/ ALUM.	10/21/05
2	RELOCATE SENDER & LABEL	3/23/06
3	REPLACE ALUMINUM FILL W/ MOLDED	6/27/09

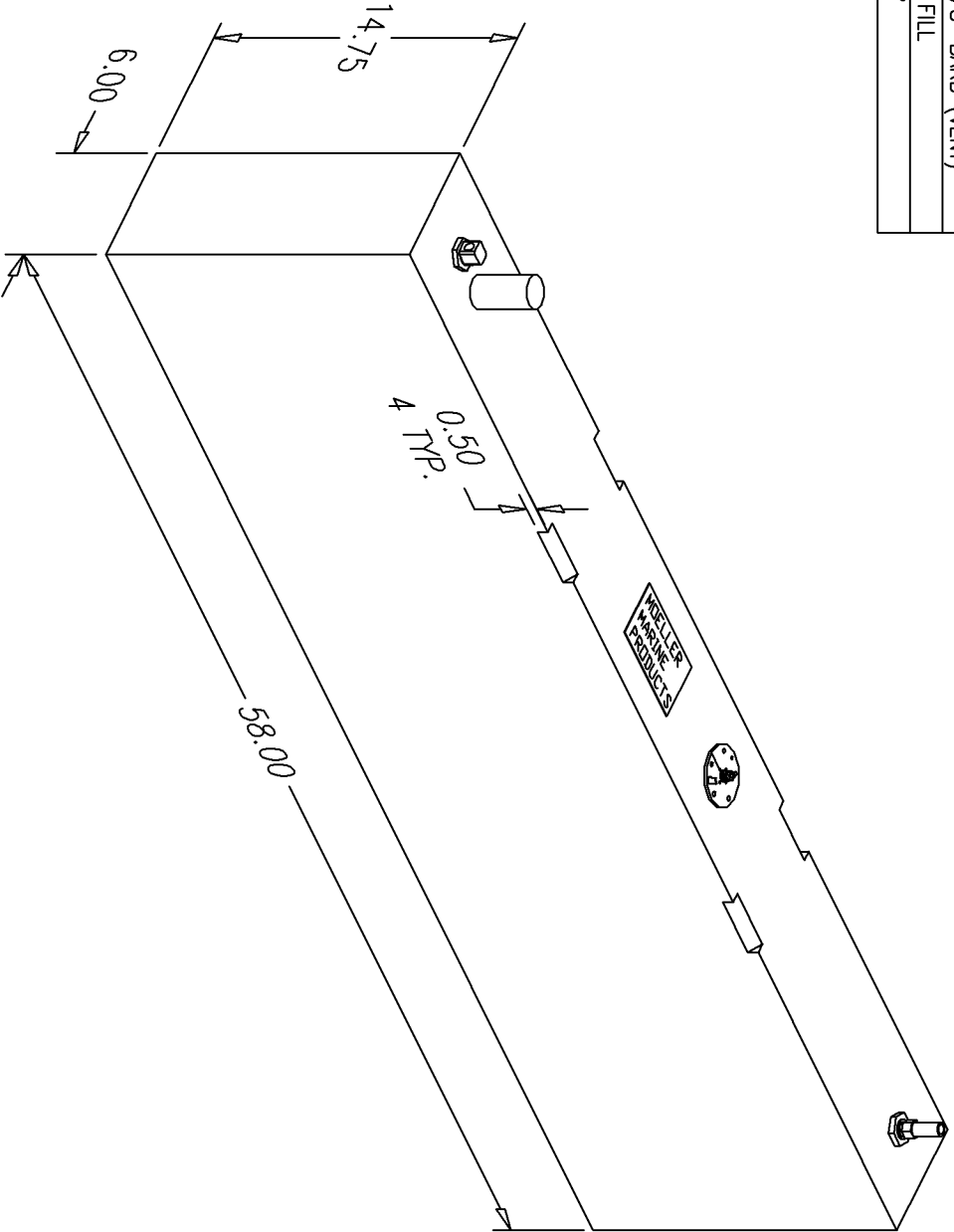

NOTE: ALL EDGES HAVE R0.375
UNLESS OTHERWISE NOTED

PAGE 1 OF 2

THIS DRAWING AND THE ATTACHED DRAWINGS (AND THE DATA SHOWN THEREON) IS CONFIDENTIAL AND PROPRIETARY AND SHALL NOT BE USED, DISCLOSED TO OTHERS, REPRODUCED FOR ANY PURPOSE EXCEPT FOR QUOTATION TO OR ORDER BY MOELLER MARINE PRODUCTS, INC. AND/OR IT'S SUBSIDIARIES WITHOUT THEIR WRITTEN CONSENT TO THE USE OF SUCH DRAWINGS AND/OR DATA.

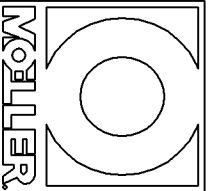

DESCRIPTION	20 GALLON FUEL TANK
PART #	FT2098
MATERIAL	CROSSLINK POLYETHYLENE
TOLERANCES	±1.5% UNLESS OTHERWISE NOTED
WALL THK.	0.200"
DRAWN BY	MOELLER ENGINEERING

